

FOUR-BIN MAILBOX
(Machine Code: G518)

1 OVERALL MACHINE INFORMATION

1.1 SPECIFICATIONS

Number of Trays	4
Tray Capacity:	125 sheets (80 g/m ² , 20 lb)
Paper Size for Trays:	Maximum: A3 or 11" x 17" Minimum: A5 (LEF) or 11" x 8 1/2" Executive SEF (7.25" x 10.5") can be used
Paper Weight:	60 ~ 105 g/m ² , 16 ~ 28 lb
Power Consumption:	17 W or less (average)
Power Source:	DC 24 V, 5 V (from the printer)
Dimensions (W x D x H)	440 x 520 x 370 mm (17.3 x 20.5 x 14.6")
Weight:	7 kg, 15.4 lb

1.2 COMPONENT LAYOUT

1.2.1 MECHANICAL COMPONENT LAYOUT

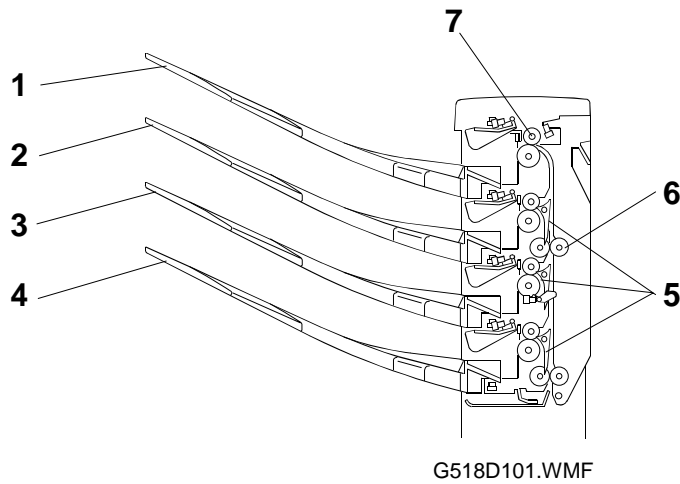

- 1. 4th Tray
- 2. 3rd Tray
- 3. 2nd Tray
- 4. 1st Tray

- 5. Turn Gate
- 6. Vertical Transport Roller
- 7. Tray Feed Out Roller

1.2.2 DRIVE LAYOUT

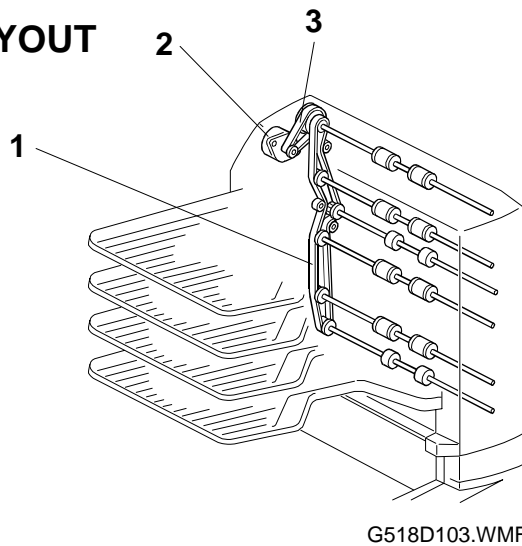

- 1. Timing Belt
- 2. Main Motor
- 3. Main Motor Timing Belt

1.3 ELECTRICAL COMPONENT DESCRIPTIONS

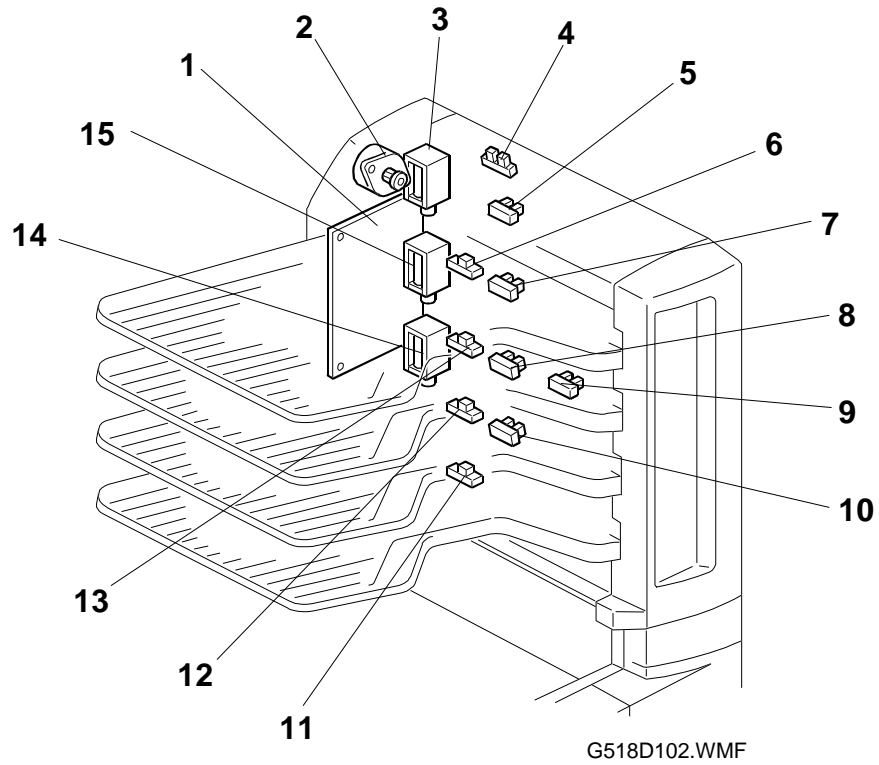

See the next page for the component description table.

Symbols	Name	Function	Index No.
Motors			
M1	Main	Drives all the mailbox rollers.	2
Sensors			
S1	Tray 4 Paper	Detects if there is paper in the 4th tray.	6
S2	Tray 3 Paper	Detects if there is paper in the 3rd tray.	13
S3	Vertical Transport	Detects misfeeds (between the 1st and 2nd trays)	9
S4	Tray 2 Paper	Detects if there is paper in the 2nd tray.	12
S5	Tray 1 Paper	Detects if there is paper in the 1st tray.	11
S6	Tray 1 Paper Overflow	Detects paper overflow in the 1st tray.	10
S7	Tray 2 Paper Overflow	Detects paper overflow in the 2nd tray.	8
S8	Tray 3 Paper Overflow	Detects paper overflow in the 3rd Tray.	7
S9	Tray 4 Paper Overflow	Detects paper overflow in the 4th tray.	5
Solenoids			
SOL1	Turn Gate Solenoid 1	Opens and closes the junction gate to direct paper into the 1st tray.	14
SOL2	Turn Gate Solenoid 2	Opens and closes the junction gate to direct paper into the 2nd tray.	15
SOL3	Turn Gate Solenoid 3	Opens and closes the junction gate to direct paper into the 3rd tray gate.	3
PCBs			
PCB1	Main Control	Controls all mailbox functions	1
Switches			
SW1	Door Safety	Cuts the dc power line when the transport cover is opened.	4

2. DETAILED DESCRIPTIONS

2.1 BASIC OPERATION

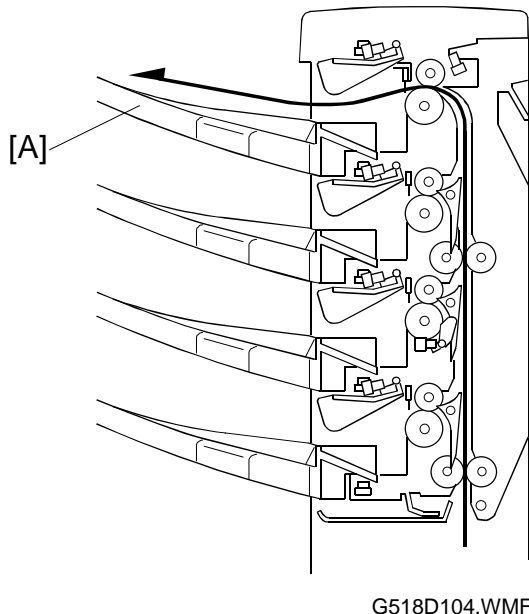

G518D104.WMF

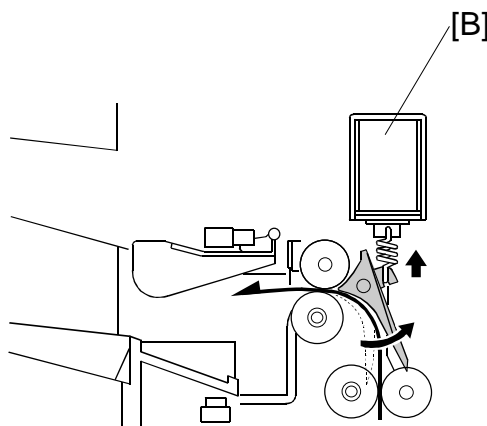

G518D105.WMF

The mailbox is connected to the main unit by a 10-pin connector.

When the leading edge of the paper activates the exit sensor on the interchange unit, the mailbox main motor turns on and the mailbox rollers begin to turn. The paper is then fed out to the tray that has been selected.

Solenoids [B] open and close junction gates as shown, to direct the paper to the selected tray. When the top tray (tray 4) is selected, none of the solenoids are activated. As the last sheet is fed out, it turns off the vertical transport sensor, and both the mailbox motor and the junction gate solenoid of the selected bin turn off.

The mailbox normally feeds paper at 121 mm/s. For the G038 printer, this is about equal to the speed of the printer itself (actual transport speeds are: 121.6 mm/s and 120.6 mm/s, respectively).

2.2 PAPER OVERFLOW DETECTION

2.2.1 OVERVIEW

The overflow sensors are installed on each tray. They monitor the trays so that the amount of paper present does not exceed the tray capacity. If a printing job is done that exceeds the capacity of one or more of the trays, the main unit recognizes the overload, displays an error message and stops the printing job. However, if the excess paper is removed from the overloaded tray, the printing job will continue.

2.2.2 DETECTION TIMING

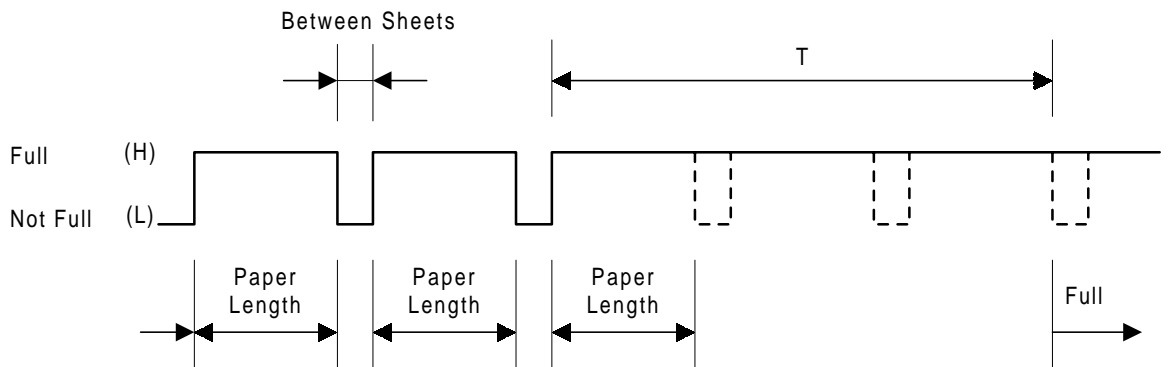

G518D107.WMF

When the sensor output is high for longer than T (calculated by the equation below), the machine determines that the tray is full.

The detection timing for a full tray is calculated by the equation below for each paper size. For example, with a minimum ppm of 12 prints (for A3), the value of T would be 15 seconds. Therefore, if the sensor continuously detects paper for 15 or more seconds (as it would if the tray were actually full and a given sheet of paper was stopped at the sensor), the machine stops the copy job, assuming that the tray is full. The value of T will be different for each paper size, since the value of ppm will vary with size.

$$T \text{ (seconds)} = (60/\text{min. PPM}) \times 3 \quad * \text{ PPM} = \text{prints per minute.}$$

2.3 PAPER MISFEED DETECTION TIMING

A4 sideways (longedge) paper to exit to the 1st bin tray

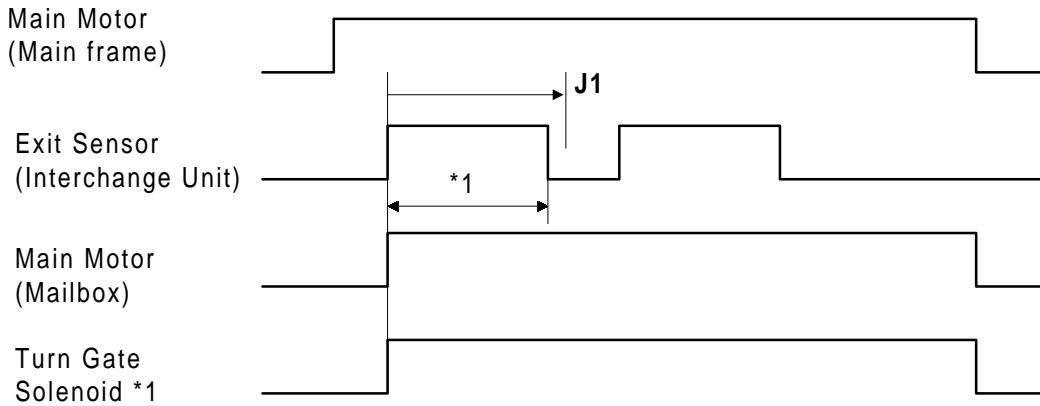

*1: Time required for A4 longedge paper

A4 sideways (longedge) paper to exit to the 2nd, 3rd, or 4th tray

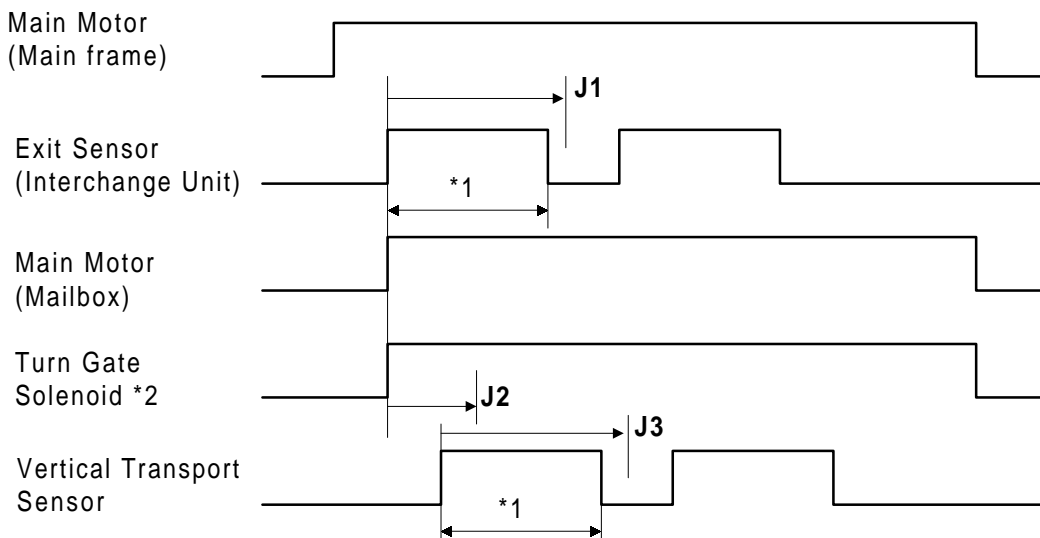

*1: Time required for A4 longedge paper

*2: All solenoids stay off for feed to the 4th tray.

- J1 Timing:** After the leading edge of the paper activates the exit sensor of the interchange unit, a misfeed is detected if this sensor does not turn off within $X + 0.52$ s, where X is equal to the amount of time a given paper size takes to pass the sensor (e.g. A4 - sideways = 1.74 s).
- J2 Timing:** After the paper exit sensor of the interchange unit is activated, the machine determines that the paper has not yet fed and detects a misfeed if the vertical transport sensor does not activate within 1.94 s (in the case of A4 paper).
- J3 Timing:** After the vertical transport sensor is activated, a misfeed is detected if this sensor does not turn off within $X + 0.52$ s (see above for an explanation of X). For example, this value would be 2.26 s for A4 sideways.

3. REPLACEMENT AND ADJUSTMENT

3.1 EXTERIOR COVER REMOVAL

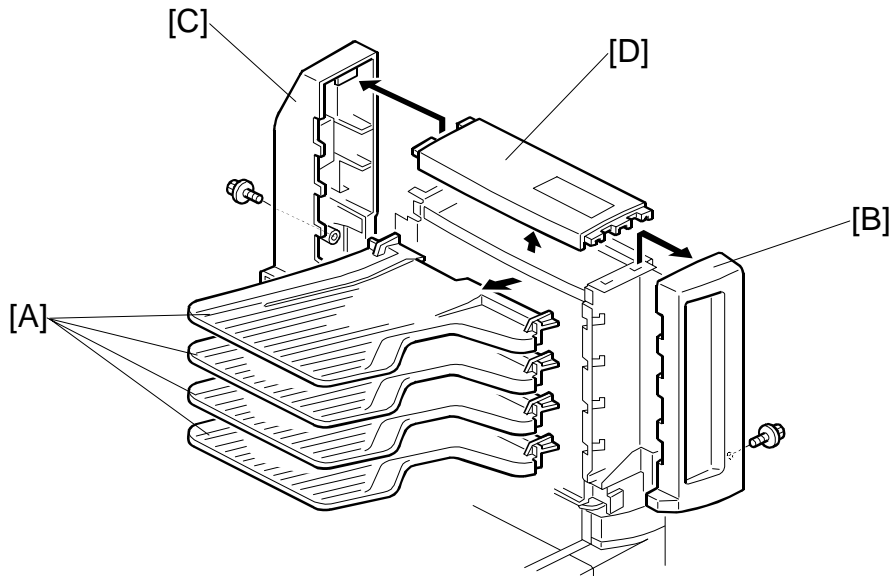

G518R101.WMF

1. Turn the main switch off and remove the power cord from the outlet.
2. Take out each tray [A] (lift by the edges).
3. Remove the front cover [B] (1 screw).
4. Remove the rear cover [C] (1 screw).
5. Remove the upper cover [D].

3.2 OVERFLOW AND VERTICAL TRANSPORT SENSOR

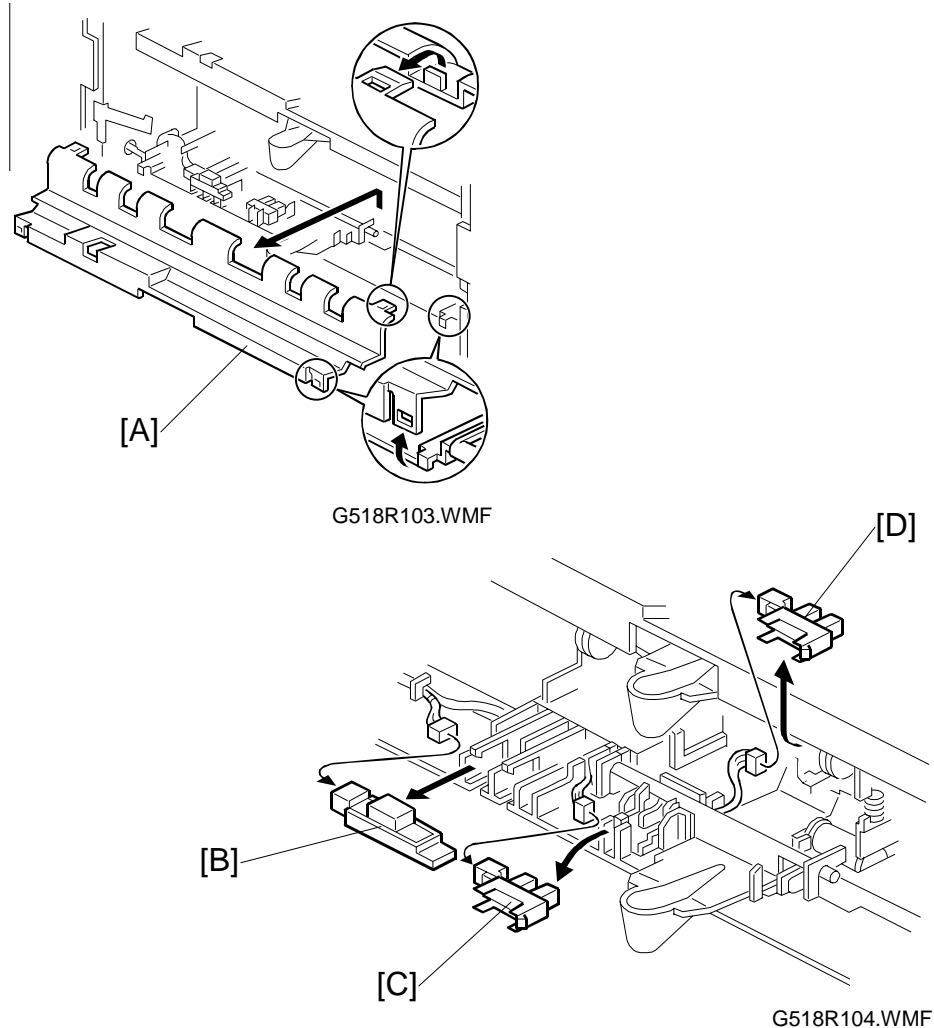

1. Turn the main switch off and unplug the power cord.
2. Remove each tray.
3. Remove the bin covers [A].
4. Remove the connector of the tray sensor [B].
Remove the connector of the overflow sensor [C]
Remove the connector of the vertical transport sensor [D].
5. Remove both the tray and overflow sensors as shown in the illustration.
For the vertical transport sensor, lift up the locking pawls (slightly).
Remove the sensor by rotating the bottom part upward.

3.3 MAIN MOTOR REPLACEMENT

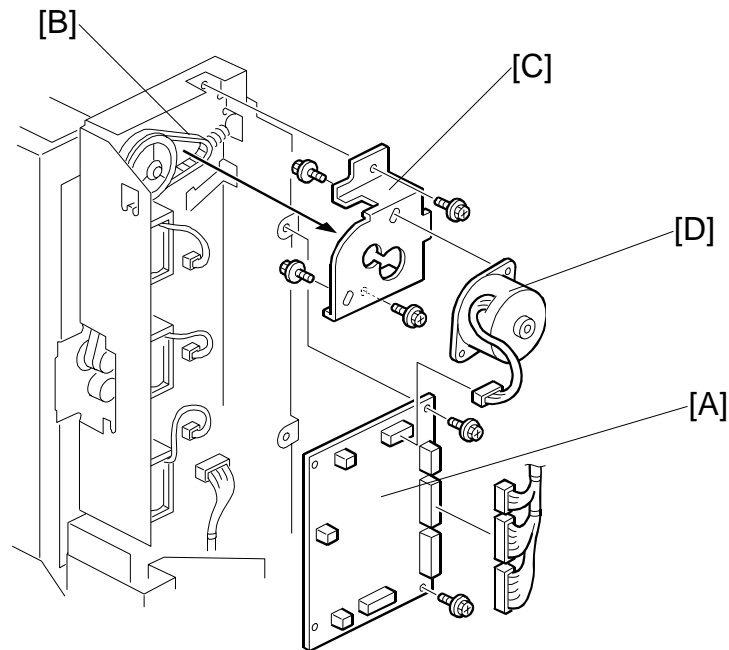

G518R102.WMF

1. Turn the main switch off and unplug the power cord.
2. Remove the rear cover.
3. Remove the control board [A] (2 screws, all connectors).
4. Remove the timing belt [B] (2 screws) and the main motor bracket [C].
5. Replace the main motor (2 screws) [D].